

SCHOOL WATER SUPPLY FLUORIDATION



ENVIRONMENTAL PROTECTION AGENCY

WATER SUPPLY DIVISION

School Water Supply Fluoridation

by

Ervin Bellack

ENVIRONMENTAL PROTECTION AGENCY

OFFICE OF WATER AND HAZARDOUS MATERIALS

WATER SUPPLY DIVISION

WASHINGTON D. C.

First printed 1972

Reprinted 1975

School Water Supply Fluoridation

After 25 years of progress, the fluoridation of community water supplies has become a widely accepted practice, and with the adoption of legislation in many States, the trend is toward almost universal treatment of these supplies with fluoride. Yet, very little progress has been made toward extending the benefits of fluorides to the 46 million persons, about 23% of the total population, who reside in areas not served by central water supply systems.¹ A number of alternative methods for providing dental caries protection for these people have been suggested; among them individual home fluoridators, fluoride tablets, and the fluoridation of the water supplies of rural schools. This latter method seems particularly appealing, since it would reach sizeable numbers of children with minimal demands on personnel, equipment, and funds.

There are some basic differences between municipal and school fluoridation which prevent drawing a direct parallel between the two methods. One of the obvious limitations imposed on school water fluoridation is that children are 5 or 6 years old before they begin attending school and consuming the water, whereas maximum dental benefits appear to accrue when fluoridated water is consumed from birth.²⁻⁴ However, in communities that have instituted controlled fluoridation, data have been obtained which indicated that children who are 6 years old or older at the time fluoridation is initiated do derive considerable benefits from the procedure.⁵⁻⁷ The potential for caries inhibition would be greatest in the later erupting permanent teeth, but there is evidence that teeth already erupted derive some caries-inhibitory benefits from the topical action of fluoridated water.⁸⁻¹⁰

A second factor limiting the effectiveness of having only the school water supply fluoridated in a community is that the exposure to fluoridated water in a school is intermittent, since children attend school only five days a week for only part of the day and for only part of the year. Recent studies, however, have reported that some benefits are derived from belated and intermittent exposure to fluoridated water, and these findings have led to the hypothesis that control of dental caries can be expected from the fluoridation of school water supplies, particularly if the level of fluoride is maintained at a concentration high enough to compensate for the late and limited exposure factors discussed.¹¹⁻¹⁴

STUDIES OF EFFICACY

A pilot study testing this hypothesis was instituted in 1954 in the Virgin Islands.¹⁵ In an attempt to duplicate the total fluoride intake of children who drank optimally fluoridated water on a full-time basis, the water supplies of two schools were fluoridated at a level approximately three times that recommended for community fluoridation in the area. A dental survey conducted after six years of school fluoridation showed that children in one of the test schools which had a record of fairly continuous operation had about 22% fewer cavities than did children who attended comparable schools without fluoridation.

Two additional school fluoridation studies were begun in 1957. In Pike County, Kentucky, the fluoride levels in two schools were maintained at 3.3 times the recommended optimum for community fluoridation, and in Elk Lake, Pennsylvania, the level was maintained in another school at 4.5 times the recommended optimum for community fluoridation. Final results from these studies are not yet available, but interim results after eight years of school fluoridation showed reductions in decayed teeth approaching 35% at each of the study sites.^{16, 21}

SAFETY

Since the raising of the fluoride level in the school fluoridation studies mentioned above resulted in greater decay reduction, it has been theorized that still higher levels might impart even greater benefits. However, the question of safety must always be considered, since it is known that full-time exposure to fluoride levels even as low as twice the optimum can cause some degree of dental fluorosis. Yet, findings of epidemiological studies have shown that children who consume water at home that was virtually fluoride-free, but who, when at school, drank water with natural fluoride levels of 6¹⁷ and 14 ppm,¹⁸ were uniformly free of any objectionable signs of dental fluorosis. Data obtained from examinations for fluorosis on children participating in the school fluoridation studies in Elk Lake are in keeping with these results.¹⁶ An examination of 281 children at Elk Lake, after eight years of school fluoridation at 4.5 times the optimum level showed that only one child was classified as having definite fluorosis, and this was of the very mild type.¹⁶ In fact, the effect of school fluoridation at somewhat elevated fluoride levels may provide an improved aesthetic appearance.

SELECTING A SCHOOL

Two of the primary requirements for school fluoridation are that the students of the school do not consume fluoridated water from any other source and do not receive dietary fluoride supplements. The requirement with respect to fluoridated water can usually be met when the school enrollment comes from a community which does not have municipal fluoridation,

or when the students come from homes which have individual well water supplies. In the former case, the possibility of eventual community fluoridation should be carefully considered, and if there is even the slightest possibility of such an event, it would be more advantageous to work toward fluoridation of the entire water supply rather than that of each individual school. In the latter case, a representative number of the individual well supplies should be checked to verify the lack of significant concentrations of natural fluoride. This level, established solely on an empirical basis, should be no greater than one-third the optimum for community fluoridation in the geographic area. An individual well supply for the school is also a mandatory requirement, since the engineering problems involved in fluoridating a single building or group of buildings on a municipal water supply are prohibitive, and there is always the possibility that the municipality will institute community fluoridation, affecting not only the school, but probably the homes of the students as well.

In fluoridating a school water supply to levels greater than established optimum levels for a community water supply, besides determining that the students do not receive fluoride supplements and are exposed to no other source of fluoridated water, there also exists the problem of having private residences connected to the school water system. The latter situation may occur in rural schools, where the principal, maintenance personnel, or other staff and their families live in homes on the school grounds. To avoid the full-time exposure of very young children in those families to high levels of fluoride, provisions must be made to exclude these residences from the fluoridated water. In most cases it will be a matter of doing a little more plumbing to isolate a residence from the high-fluoride water. Specifically, the take-off point for the residence water supply will have to be relocated to a point between the well pump and the fluoride-injection and metering point, and a backflow prevention device added to the pipe line to prevent the fluoridated water from flowing toward the house when the pump is idle or inoperative for some reason. Depending on individual circumstances, a separate hydropneumatic tank and pump controls may be required.

IMPLEMENTATION

The engineering aspects of school water fluoridations, with the exception of maintaining a higher fluoride level, are fundamentally similar to those of community water fluoridation. Essentially, a school water supply is the same as that of many small communities, and usually consists of an unattended well pump, a storage tank (either elevated or hydropneumatic) and a distribution system. The fluoridation installation consists of a solution container, a solution feeder and, for the purpose of maintaining records, a water meter. The fluoride feeding equipment used in the study projects has varied depending upon the size of the water system, its complexity and the conveniences to the operator that were built into the system. The adequacy and quality of the water supply, its pressure and storage capacity and the type and availability of personnel to operate the system were also important determinants in selecting equipment.

The earliest study projects utilized a small solenoid-operated diaphragm feeder, and the source of fluoride ion was a solution of magnesium silicofluoride. This particular chemical was chosen because solutions had to be centrally prepared, and the high solubility of magnesium silicofluoride permitted preparation of stronger solutions and thus, less frequent refills. These early studies were also dependent on centrally-located operators, such as county or state public health personnel, for surveillance and maintenance. Experience has shown that the installation should be designed to be as simple and trouble-free as possible in order to assure uninterrupted operation, and that a local operator, such as a high school science teacher, a principal, or a custodian at the installation site is a better choice than a centrally-located operator. Since schools having their own water supplies are usually rural, they are usually located at considerable distances from a county or state health agency capable of providing the skills necessary for surveillance and maintenance. Thus, when an adjustment of fluoride level is indicated or mechanical failure occurs, there is inevitably a delay before adjustment or repairs can be effected. If, on the other hand, the installation is operated by interested local personnel, any delay is minimal. With adequate training, almost anyone can perform routine fluoride analyses and maintain the equipment, provided of course, the type of equipment is tailored to the skill and experience of the operator. Although individual circumstances may dictate other choices, the use of local operators has resulted in the evolution of an installation design based on the use of a sodium fluoride saturator, a device for providing a constant supply of fluoride solution of fixed strength with minimal operator attention.

PROCEDURE

Although specific details regarding the equipment and facilities applicable to all school fluoridation installations cannot be prescribed due to the widely varying conditions existing at each prospective site, a generalized step-by-step procedure having wide application has been derived, based on the design mentioned above. Before the actual installation of any fluoridating equipment can be made, however, it must be ascertained that the school meets the previously specified requirements, that all necessary approvals have been obtained, and the level of fluoride to be fed has been agreed upon. (A level of four and one-half times the optimum for community fluoridation in the geographic area is currently recommended by the U. S. Public Health Service.)

Step I: Locate the point in the system where the water flow represents the total output of the well or spring, and where the flow is maintained at the operating pressure of the school water system. This point will be the site of fluoride injection and flow metering so its selection is of primary importance. The fluoride injection point may be adjacent to the well or spring itself, in a crawl space under the school building, or adjacent to the hydropneumatic tank or elevated storage tank. If one of the latter sites is chosen for flow metering and fluoride injection, the absence of branch lines

between the well and the pressure tank must be positively verified. If branch lines do exist, and particularly if a line to a residence exists, the fluoride injection and flow metering point must be located so that the former are included in the system to be treated, while the latter is specifically excluded. This may involve relocating a pipe line, as mentioned earlier. Under no circumstances should a point in the output of the water storage facility be selected as the fluoride injection and flow metering point, for there the water flow may vary from zero (when the storage merely "rides" on the system) to the maximum capacity of the system derived from pipe size and pressure. The simplicity of the installation is dependent on a flow rate which is essentially constant, as typified by the flow between a well or spring box pump and storage facility.

Step II: When the metering point is located, determine the pump delivery rate. This may be recorded or available from the pump manufacturer, or can be estimated from the horsepower rating, well depth (if known) and head loss. When figures are lacking or questionable, as is usually the case, flow rate at zero pressure must be measured at the metering point by opening the pipe line and checking the flow with a calibrated bucket or 55-gallon drum and stopwatch. The figure thus obtained must then be adjusted to the intermediate pressure of the hydropneumatic tank or elevated storage. The pump manufacturer, a well-pump installer, or a sanitary engineer should be consulted for assistance in determining the amount of flow reduction resulting from system pressure.

Step III: Locate space for installation of the feeder and solution tank. If the pump and injection point are in a well house, and the well house is spacious and dry, this is the ideal situation, for then the installation can be neat and compact (Fig. 1). However, such is not always the case and equipment must be placed in an adjoining building, in the school basement, or in a small shelter built for the installation. It is preferable to have the equipment as close to the metering point as possible.

Step IV: Determine specifications for the master meter and feeder. For economy and best accuracy, the meter should be as small as flow conditions will permit. However, the pipe size at the metering point and the pump capability are also factors to be considered. If a pressure loss of several pounds per square inch can be tolerated, the pipe can be reduced with fittings to accommodate a smaller meter. The feeder size depends on the water flow rate and the fluoride level decided upon, as well as on the concentration of fluoride solution to be used. If a saturator is used, the solution produced is approximately 18,000 ppm F, so the feeder delivery rate in gallons per hour (gph) will be: pump rate (gph) X desired F (ppm)/18,000 ppm. For example, if the pump rate is 12 gallons per minute and the desired fluoride level is 6 ppm, the feeder delivery rate in gallons per hour will be:

$$\frac{12 \times 60 \text{ (Min/Hr)}}{18,000} \times 6 = .24 \text{ gph}$$

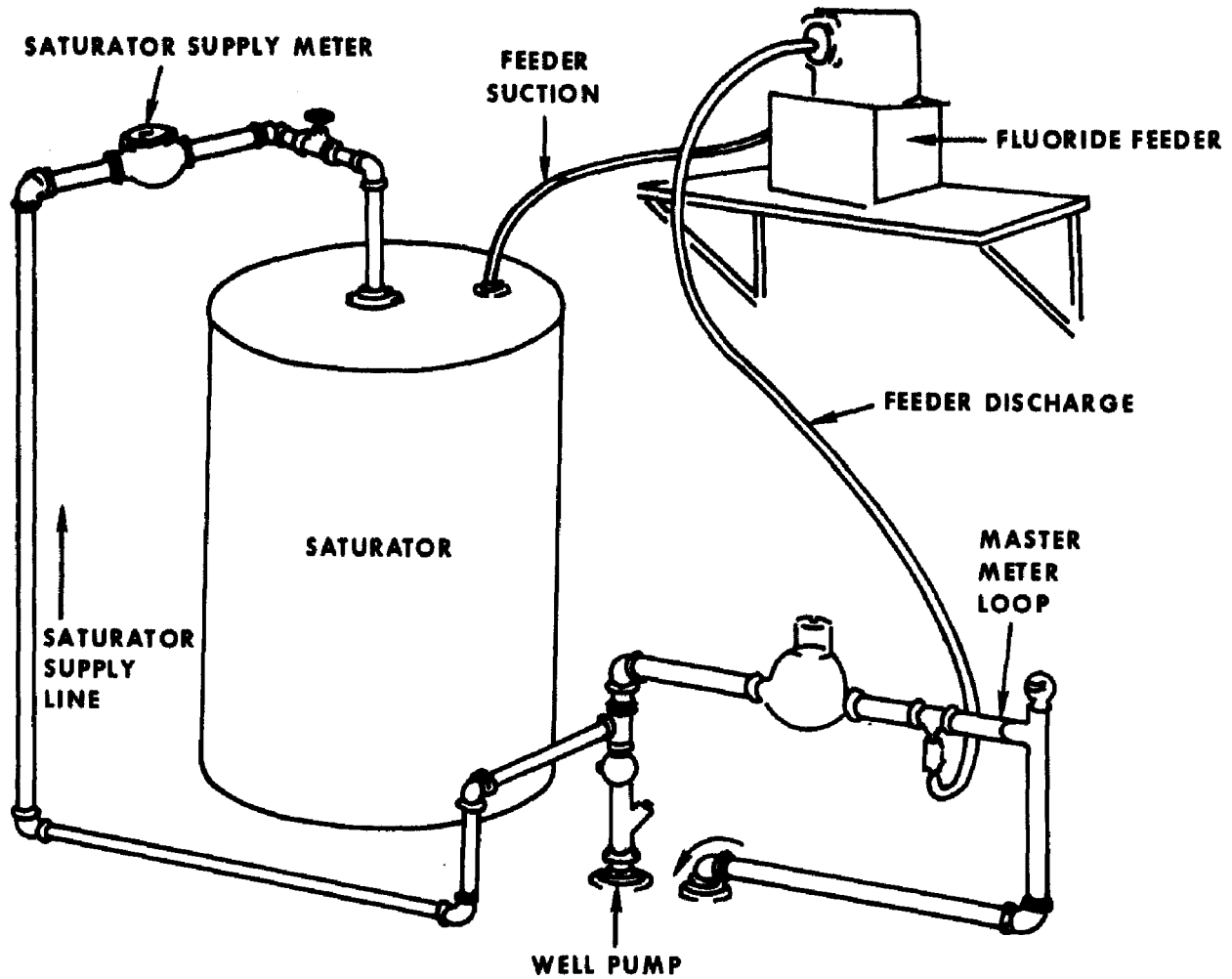

Figure 1. Pump Room

With this figure, a feeder can be specified, bearing in mind that most chemical feeders operate best at midrange, and that the estimate of the pump delivery rate is subject to revision. For the low flow rates usually encountered in school water systems, diaphragm-type feeders having resilient check valves are usually the best choice. Because the feeder will be electrically cross-connected to the pump circuit, an independent motor drive with 3-step pulley will also lend flexibility to the arrangement. For simplicity in making electrical connections, the motor should have the same electrical requirements as the pump, for example, a 220-volt motor and a 220-volt well pump. An electrician can identify the voltage and phase characteristics of the pump if they are not already known.²⁰ Feeder head construction materials for handling saturated sodium fluoride solutions are readily available.

Step V: Once the master meter and solution feeder have been specified and obtained, installation is begun by:

(A) Opening the pipe line for insertion of the meter, injection tee, strainer, check valve, saturator supply tee, vacuum relief valve and other fittings as required. The fluoride injection should be at the bottom of the pipe to prevent air binding, so it may be necessary to raise the pipe line. If insufficient space is available for the meter and other appurtenances, a loop in the pipe line must be made. For buried or close-to-the-floor pipe, a vertical loop will generally be applicable (Fig. 2). The installation of shut-off valves at appropriate points will make maintenance of the system parts more convenient. Where the pump is a submersible type in a well, the use of pipe unions will facilitate removal of equipment so that the well pump will be accessible for repairs. Special conditions apply if the pump is a reciprocating type. Specifically, with a reciprocating pump, the inclusion of a surge chamber is a necessity to prevent damage to the meter and to permit the use of a flow switch. A flow switch is also recommended whenever there is a distinct possibility of pump failure and resultant fluoride overfeed. The flow switch, in series with the feeder motor, should be set so that the circuit is broken when the well pump delivery falls below the figure established as the normal flow rate at the time the installation was designed.

(B) Connect a pipe line to the saturator supply tee and run it to the saturator position, incorporating a small water meter where convenient. A shut-off valve should be placed between the meter and the saturator to permit manual control of the saturator supply.

Step VI: Install the saturator so that it is level and the filling-gate is accessible. If necessary, connect a drain line to the overflow. Install the feeder so that it is above the saturator and so that the intake line is as short and straight as possible. A small shelf a short distance above the top of the saturator will provide a convenient base for the feeder. Cross-connect the feeder motor electrically to the well-pump circuit so that the feeder will run whenever the well pump does. If a flow switch is used, connect it in series with the feeder motor.

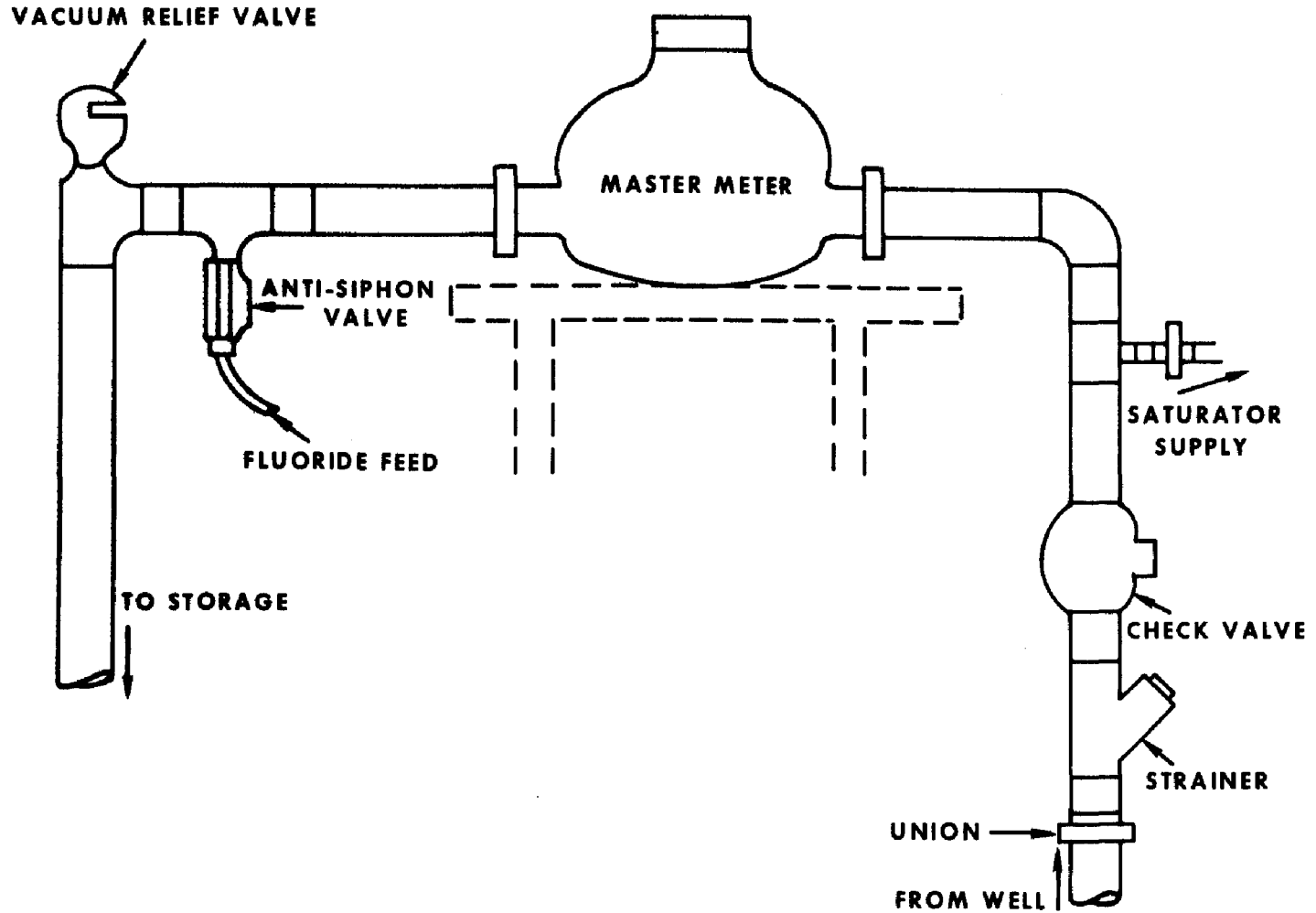

Figure 2. Master Meter Loop

Step VII: After all electrical and plumbing connections are made, connect the feeder discharge tube to the injection tee, making sure all check valves are positioned so that fluoride solution can be fed into the line but water cannot flow toward the feeder. Insert the suction tube into the saturator, and inspect the check valves for proper position. The suction tube should terminate a few inches above the bottom of the saturator and should be equipped with a foot-valve and strainer. Prepare the saturator by placing gravel carefully around the cone, adding sand, leveling the sand surface and then adding crystalline sodium fluoride (Fig. 3). The sodium fluoride should be preferably 40 to 60 mesh, but slightly finer crystals can be used. Under no circumstances may powdered sodium fluoride be used, since it will sift through the sand and gravel and be pumped as a slurry. Also, water will not percolate freely through fine powder. After leveling the surface of the fluoride layer, admit water to the saturator and adjust the float valve so that the water cut off is slightly below the overflow. The saturator will hold 200 pounds of fluoride, or more, but in some cases a depression will have to be made in the surface of the fluoride to permit operation of the float. Prime the feeder and adjust the feed rate to correspond to previous calculations. Most small diaphragm-type feeders can be primed by loosening the discharge cap and jiggling the suction tube up and down. This causes liquid to rise in the suction tube until it reaches the pumping chamber. Retighten the discharge cap and other fittings and start the well pump. Take readings of both the master meter and the small meter on the saturator water supply line.

Step VIII: Recheck the well-pump delivery rate, using the master meter and stop watch through several cycles of high and low pressure. If necessary, readjust the feeder. After a few hours of operation, sampling can begin. Choose a sampling point where there is considerable water usage so samples will be representative. Depending on the system layout, it may take considerable time for the system to become completely fluoridated. This is especially true when there is a storage reservoir "riding" on the system. Fluoride concentrations should rise gradually and then reach an equilibrium.

SURVEILLANCE

After equilibrium has been reached, the desired fluoride level achieved and the system stabilized, about 20 to 25 water samples should be taken throughout the system and analyzed for fluoride content. These samples can form the basis for a study of the inherent variability in the system. The variability of fluoride concentration in the samples is used to determine action and warning limits for a quality control chart¹⁹ (Fig. 4). The great advantage of the quality control chart as a surveillance tool is that it is easy to maintain. It permits historical comparisons with present observed variability and encourages adjustment of the process when the limits are violated. As the overall variability in the process is reduced, narrower action and warning limits can be established above and below the desired target level.

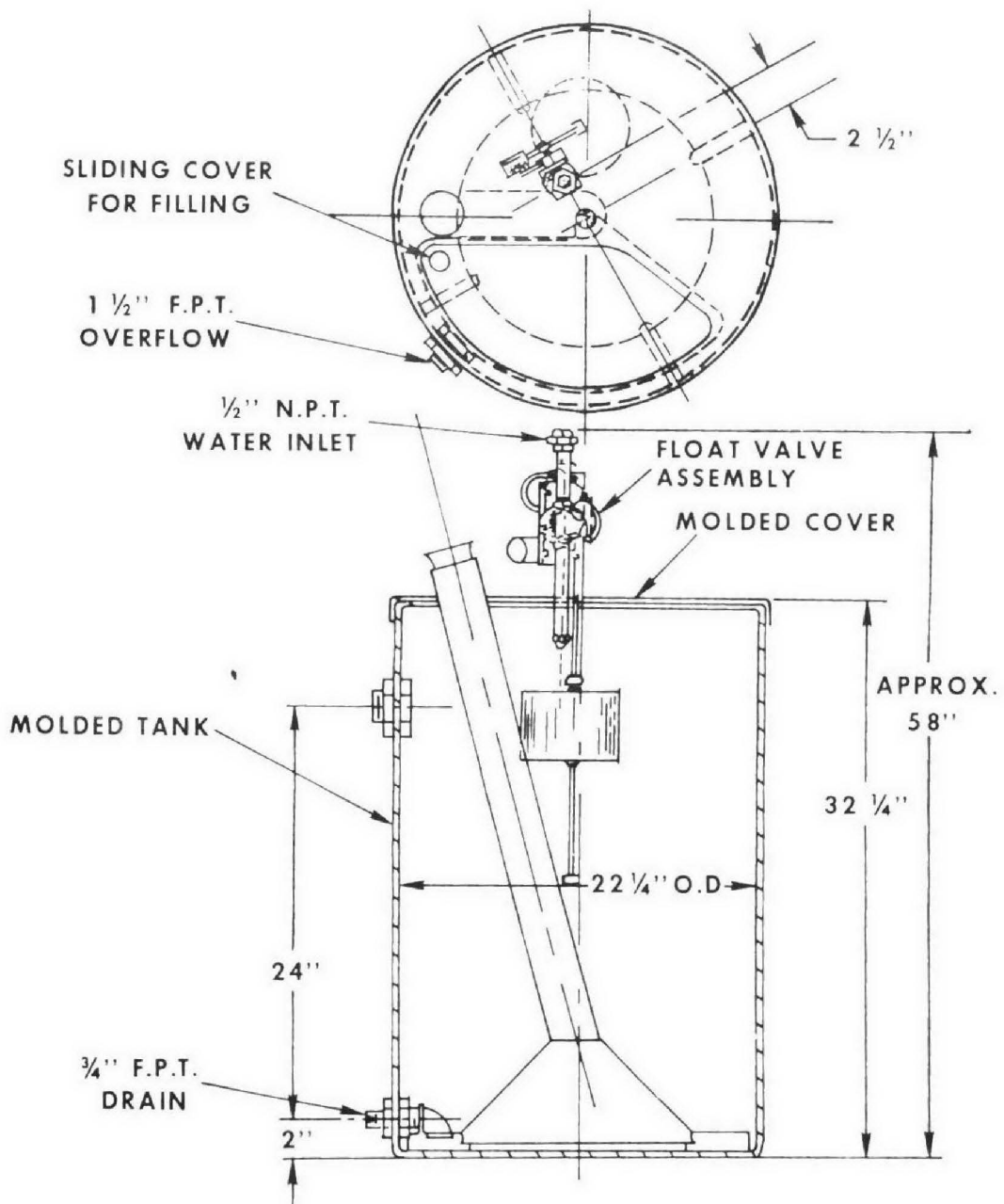

Figure 3. Sodium Fluoride Saturator

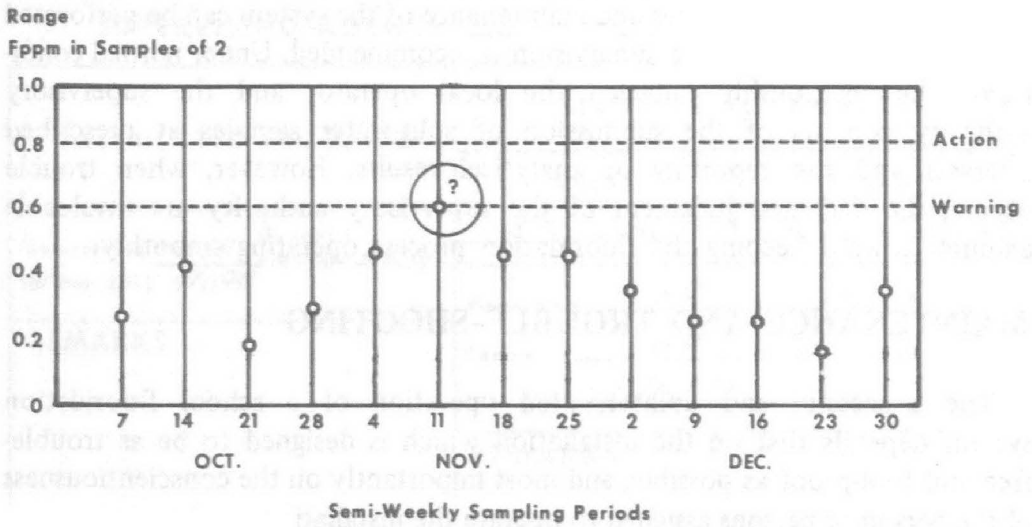
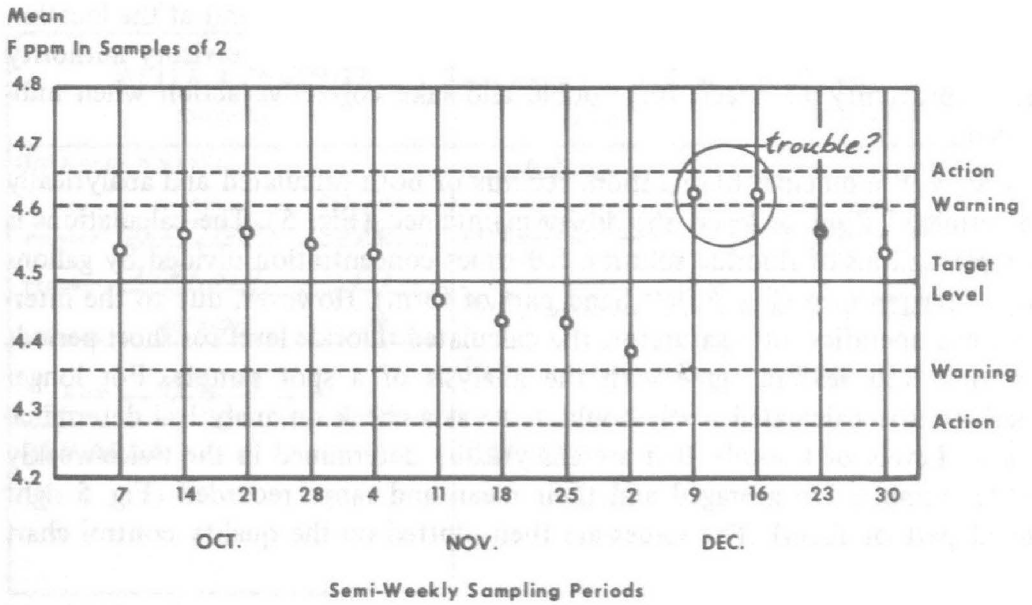

Figure 4. Quality Control Chart, School Fluoridation

Fluoride sampling for operational control should follow a predetermined schedule. A minimum of two samples a week is the suggested sampling frequency and one of the samples should be sent to the supervisory authority, such as the State Health Department Laboratory, to enable duplicate fluoride analyses to be performed. When the quality control chart reveals that the process is relatively stable, split-sample analyses can be done less often. It is recommended that quality control charts be kept at the fluoridation site and at the location of the supervisory authority to afford the operator and supervisory authority an opportunity to check for trouble and take corrective action when indicated.

As with municipal fluoridation, records of both calculated and analytically determined fluoride levels should be maintained (Fig. 5). The calculations is simple—gallons of fluoride solution fed times concentration divided by gallons of water pumped (Fig. 5, left hand part of form). However, due to the intermittent operation of a saturator, the calculated fluoride level for short periods of time will seldom agree with the analysis of a spot sample. For longer periods, the calculated level should serve as a check on analytical determinations. Levels of fluoride that are analytically determined in the twice-weekly water samples are averaged and their mean and range recorded (Fig. 5 right hand part of form). The values are then plotted on the quality control chart (Fig. 4).

Although routine analyses and maintenance of the system can be performed by the local operator, some supervision is recommended. Under normal conditions, the relationship between the local operator and the supervisory authority consists of the submission of split-water samples at prescribed intervals and the reporting of analytical results. However, when trouble occurs, the skill and judgment of the supervisory authority are invaluable adjuncts toward keeping the fluoridation process operating smoothly.

MAINTENANCE AND TROUBLE-SHOOTING

The successful and uninterrupted operation of a school fluoridation system depends first on the installation which is designed to be as trouble-free and fool-proof as possible, and most importantly on the conscientiousness of the person or persons assigned to operate the installation.

The operation of the saturator can be checked by taking a sample of solution from inside the cone, diluting (stepwise) down to a level within the analytical range and performing a fluoride analysis. If the dilution is careful and the analysis accurate, a 4% sodium fluoride solution should read from 17,000 to 18,000 ppm F. The feeder operation (against pressure) can be checked by removing the suction tube from the saturator, inserting it in a water-filled graduated cylinder (without losing prime) and with the aid of a stop watch, measuring the feed rate while the water supply pump is running.

SCHOOL _____

METER READINGS (Gallons)	WEEKLY WATER SAMPLES	
	FIRST	SECOND
(Take once a week)	<u>6.8</u> ppm Fluoride	<u>7.0</u> ppm Fluoride
Present $\frac{\text{Water } 3029,150}{\text{Saturator } 880}$	Date <u>10/6/70</u>	Date <u>10/8/70</u>
Previous <u>2987,460</u> <u>866</u>	Mean ppm <u>6.9</u> $\left\{ \frac{1st+2nd}{2} \right\}$	
Difference <u>41,690</u> <u>14</u>	Range <u>0.2</u> (highest minus lowest)	
Date <u>10/6/70</u>		
REMARKS	REMARKS	

SUPERVISING AGENCY _____

CALCULATED FLUORIDE	SPLIT-SAMPLE ANALYSIS	
	FIRST	SECOND
(Saturator diff.) <u>14</u> (F. conc.) (Water diff.) <u>41690</u> $\times 18,000 =$ <u>6.0</u> ppm	<u>5.7</u> ppm Fluoride	<u>6.1</u> ppm Fluoride
REMARKS	Mean ppm <u>5.9</u> $\left\{ \frac{1st+2nd}{2} \right\}$	
	Range <u>0.4</u> (highest minus lowest)	
	Date <u>10/12/70</u>	
	REMARKS	

Figure 5. School Fluoridation Fluoride Analysis Form

Besides maintaining a supply of fluoride in the saturator, keeping the feeder lubricated and leak-free, the operator's principal function is to maintain the desired fluoride level within the limits established. Because a skilled analyst is seldom available, the operator should be taught one of the simpler methods of fluoride analysis, taking into account the funds available for equipment, the operator's manual dexterity and particularly, the requirement that samples must be diluted. School fluoridation usually calls for fluoride levels several times the optimum for the local area, but fluoride analytical methods, except the electrode method, are limited in range so dilution of the sample is essential. The inaccuracy of a given method is multiplied by the dilution factor, so determinations by the most simple method, the visual comparator, which is also the least accurate, would be totally unsatisfactory. If the funds and skill to operate the electrode method are not available, the next choice would be the SPADNS colorimetric procedure, utilizing a spectrophotometer or more probably, one of the portable direct-reading colorimeters.^{20,22}

The possibility of designing a school fluoridation installation in which the feed rate is automatically adjusted to water flow-rate ("pacing") has been considered and tried in several instances. Unfortunately, the benefits gained have seldom justified the extra cost for equipment and the maintenance problems have been prohibitive. The systems used were based on a meter-contacter and solenoid-driven diaphragm feeder, or a water-driven feeder depending on a solenoid valve for diverting water flow as required. When the meter contacter was a mechanical switch, difficulties with sticking contacts were experienced and although the use of a mercury switch would have eliminated this problem, there were additional difficulties with solenoid valves and with the electrical circuits required to operate them. The use of motor-driven feeders necessitates the incorporation of an interval timer into the electrical system and the timer is also subject to mechanical and electrical failures. In general, then, for the sake of simplicity and ease of maintenance, a motor-driven feeder without any attempt at "pacing" is preferred.

Incorrect fluoride levels occurring in the type of installation described can be caused by a number of factors:

1. High fluoride reading -
 - a. Error in fluoride analysis
 - b. Feeder adjustment is incorrect
 - c. Failure of the saturator cone
 - d. Sifting of sodium fluoride through the sand barrier
 - e. Failure or lessened delivery of the water supply pump
 - f. Break in a water line with the failure of a siphon-breaker or vacuum-relief valve
 - g. Contamination of the sampling container

- h. Water leak between the water supply pump and injection point
 - i. Sample for fluoride analysis taken before thorough mixing
2. Low fluoride reading -
- a. Error in fluoride analysis
 - b. Feeder adjustment is incorrect
 - c. Insufficient quantity of sodium fluoride in the saturator or the fluoride is not dissolving fast enough
 - d. Loss of feeder prime
 - e. Accidental shut-off of the feeder switch or electrical failure
 - f. Lack of water supply to the saturator (accidental valve closing or improper float adjustment)
 - g. Failure of the feeder or leaking connections
 - h. Air-binding in the feeder discharge line
 - i. Feeder check-valve failure or incorrect positioning
 - j. Accidental valve closing at the injection point
 - k. Sample for fluoride analysis taken before thorough mixing
 - l. System not in equilibrium

In climatic areas subject to freezing, when the installation is located in an unheated well house or similar shelter, water meters can freeze. In such areas, water meters with frostproof construction should be specified, and in addition, some provisions for space heating should be made. In small enclosures an infrared lamp is usually adequate, but for larger buildings, a radiant panel may be required. Thermostatic control, rather than a manual switch, will insure protection of the equipment when the temperature drops.

SUMMARY AND CONCLUSIONS

The engineering aspects of school water fluoridation, with the exception of maintaining a higher fluoride level, are fundamentally similar to those of community water fluoridation. Unlike the community situation, however, there is a general lack of knowledge of the water system characteristics by the school personnel, and skilled operators are seldom available at the school site. To overcome these deficiencies, a simplified procedure for making a school fluoridation installation has been derived. The installation is based on the use of a saturator for automatically preparing fluoride solutions of fixed concentration. By choosing a point for fluoride injection where water flow and pressure are relatively constant, or at least vary only between regular limits, the need for frequent dosage adjustments is eliminated. In addition, a system for surveillance has been established which enables both the local operator and the supervisory authority to detect potential problems and take corrective action when indicated. While

both the equipment and the procedure would have wide applicability, it is readily conceded that the widely varying conditions at each prospective site may require further engineering consultation which could lead to an entirely different approach.

References

1. DHEW, U. S. Public Health Service, NIH. Fluoridation Census, 1969. GPO Publication 0-380-791, Washington, D. C.
2. Ast, D. B., Smith, D. J., Wachs, B., and Cantwell, K. T., Newburgh-Kingston Caries-Fluorine Study XIV. Combined Clinical and Roetgenographic Dental Findings After Ten Years of Fluoride Experience. *J. Am. Dent. Assoc.* 52:314-325 (March 1956).
3. Knutson, J. W., An Evaluation of the Grand Rapids Water Fluoridation Project. *J. Michigan Med. Soc.* 53:1001-1006 (Sept. 1954).
4. Russell, A. L., and Hamilton, P. M., Dental Caries in Permanent First Molars After Eight Years of Fluoridation, *Arch. Oral Biol.* (Special Supplement) 6:50-57 (1961).
5. Arnold, F. A., Jr., Dean, H. T., and Knutson, J. W., Effect of Fluoridated Water Supplies on Dental Caries Prevalence: Seventh Year of Grand Rapids-Muskegon Study. *Public Health Report* 68:141-148 (Feb. 1953).
6. Bushel, A., and Smith, D. J., Newburgh-Kingston Caries Fluorine Study. X. Dental Findings for 17-Year-Old Group After Nine Years of Fluorine Experience, *N. Y. Dental J.* 25:215-218 (June-July 1955).
7. Hill, I. N., Blayney, J. R., and Wolfe, W. The Evanston Dental Caries Study, XV. The Caries Experience Rates of Two Groups of Evanston Children After Exposure to Fluoridated Water. *J. Dent. Res.* 36:208-219 (April 1957).
8. Klein, H., Dental Caries Experience in Relocated Children Exposed to Water Containing Fluorine, II. *J. Am. Dent. Assoc.* 33:1136-1141 (Sept. 1946).
9. Russell, A. L., Dental Effects of Exposure to Fluorine-Bearing Dakota Sandstone Waters of Various Ages and for Various Lengths of Time. II. Patterns of Dental Caries Inhibition as Related to Exposure Span, to Elapsed Time Since Exposure, and to Periods of Calcification and Eruption. *J. Dent. Res.* 28:600-612 (Dec. 1949).
10. Hayes, R. L., Littleton, N. W., and White, C. L., Posteruptive Effects of Fluoridation on the First Permanent Molars of Children in Grand Rapids, Michigan. *Am. J. Public Health* 47:192-199 (Feb. 1957).

11. Klien, H., Dental Effects of Accidentally Fluorinated Water. I. Dental Caries Experience in Deciduous and Permanent Teeth of School Age Children. *J. Am. Dent. Assoc.* 36:443-453 (June 1948).
12. Yacovone, J. A., and Lisanti, V. F., Effect of Part-Time Exposure to Natural Water-Borne Fluorides on the Incidence of Dental Caries. *Arch. Oral Biol.* 1:265-275 (Jan. 1960).
13. Jordan, W. A., Ten Years of Fluoridation in Ely, Minnesota. *Northwest Dent.* 41:186-188 (May-June 1962).
14. Creighton, W. E., Savage, J., and Witter, D. M., Effect of Fluoridated Water in Schools Upon Dental Caries Susceptibility. *Pub. Health Report* 79:778-780 (Sept. 1964).
15. Horowitz, H. S., Law, F. E., and Pritzker, T., Effect of School Water Fluoridation on Dental Caries, St. Thomas, V. I., *Pub. Health Report* 80:381-388 (May 1965).
16. Horowitz, H. S., Heifetz, S. B., Law, F. E., and Driscoll, W. S., School Fluoridation Studies in Elk Lake, Pennsylvania and Pike County, Kentucky—Results After Eight Years. *Am. J. Pub. Health* 59:2240-2250 (Dec. 1968).
17. McKay, F. S. Mottled Enamel: The Prevention of Its Further Production Through a Change of the Water Supply at Oakley, Idaho. *Am. Dent. Assoc. J.* 20:1137-1149 (July 1933).
18. Kempf, G. A., and McKay, F. S., Mottled Enamel in a Segregated Population. *Pub. Health Report* 45:2923-2940 (Nov. 28, 1930).
19. Moroney, M. J., *Facts from Figures*. Third Ed. Baltimore, Penguin 1956. VII ± 472 pp.
20. Bellack, E., *Fluoridation Engineering Manual*. Water Supply Division, Environmental Protection Agency, In press.
21. Horowitz, H. S., Heifetz, S. B., and Law, F. E., Effect of School Water Fluoridation on Dental Caries: Final Results in Elk Lake After Twelve Years. *J. Am. Dent. Assoc.* Vol. 84, pp 832-838, April 1972.
22. Bellack, E., *Methods and Materials for Fluoride Analysis*, *J. Am. Water Works Assn.* 64:62-66 (Jan. 1972).